

# SECTION VII

## STOCK GUIDES

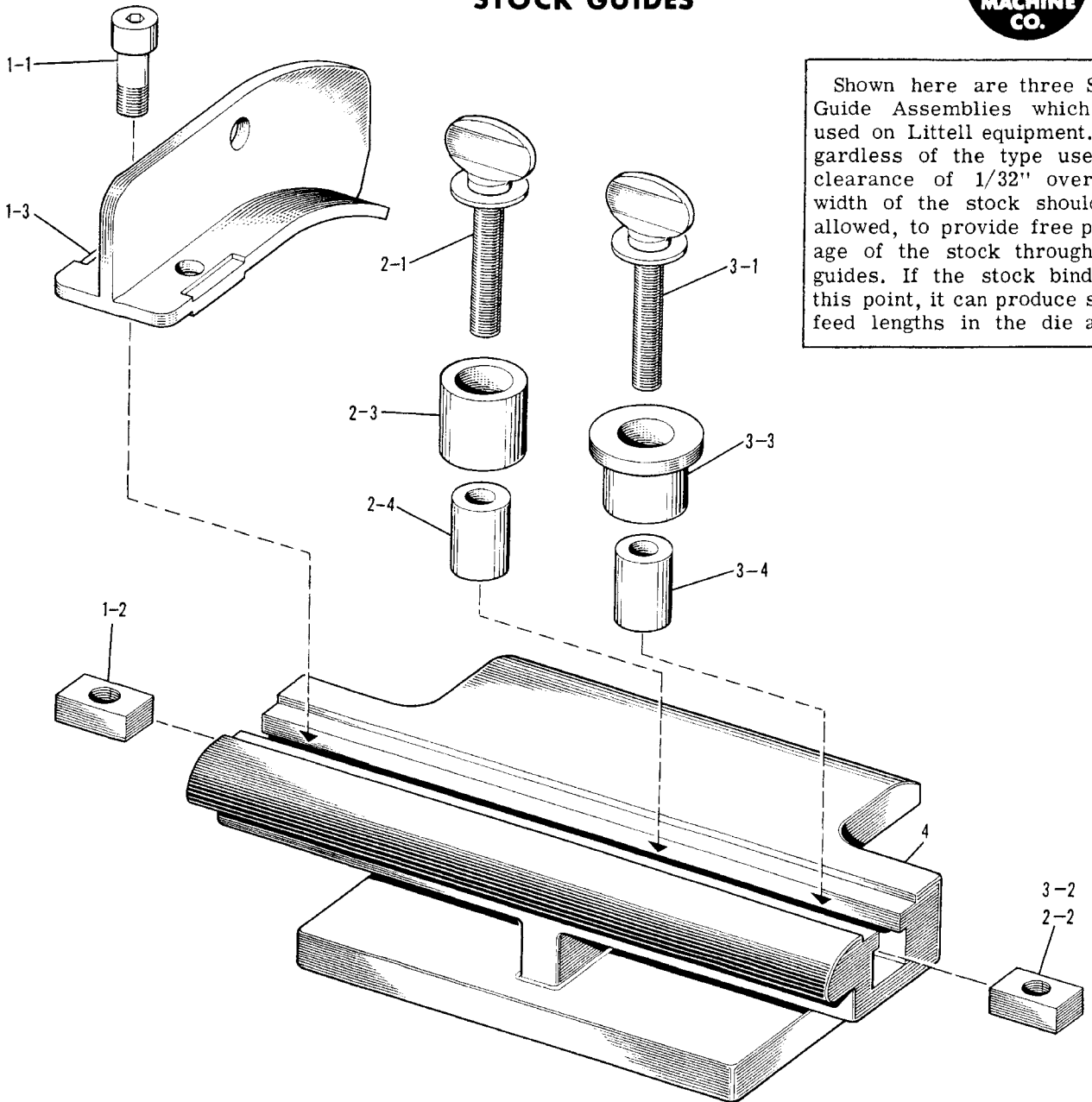

Shown here are three Stock Guide Assemblies which are used on Littell equipment. Regardless of the type used, a clearance of  $1/32''$  over the width of the stock should be allowed, to provide free passage of the stock through the guides. If the stock binds at this point, it can produce short feed lengths in the die area.

INDEX NO.	DESCRIPTION
1	Assembly - Stock Guide, "T-Iron" Consists of: 1-1 Screw - Socket-head Cap 1-2 Nut - Stock Guide 1-3 Guide - Stock, "T-Iron"
2	Assembly - Stock Guide Roller Consists of: 2-1 Screw - Thumb 2-2 Nut - Stock Guide 2-3 Roller - Stock Guide 2-4 Hub - Roller

INDEX NO.	DESCRIPTION
3	Assembly - Stock Guide Flanged - Roller  Consists of: 3-1 Screw - Thumb 3-2 Nut - Stock Guide 3-3 Roller - Stock Guide 3-4 Hub - Roller
4	Table - Stock