

## ORDERING REPLACEMENT PARTS and SERVICE ASSISTANCE

**SERVICE BULLETIN  
NUMBER SD-115 &116**

The LITTELL line of coil handling and feeding equipment is custom engineered to fit the needs and requirements of each application. For this reason, the LITTELL serial number becomes the only way to properly identify your individual machine. This number allows LITTELL service engineers to locate a complete set of records that were originally used in the engineering and manufacture of each particular machine.

From these records, we are able to duplicate almost any part made for LITTELL coil handling equipment built in the past fifty years.

The LITTELL serial number is permanently stamped on the LITTELL machine nameplate or on the base of the machine itself.

It will appear as a five digit number followed by a dash and two more digits indicating the year in which the machine was shipped from the LITTELL factory.

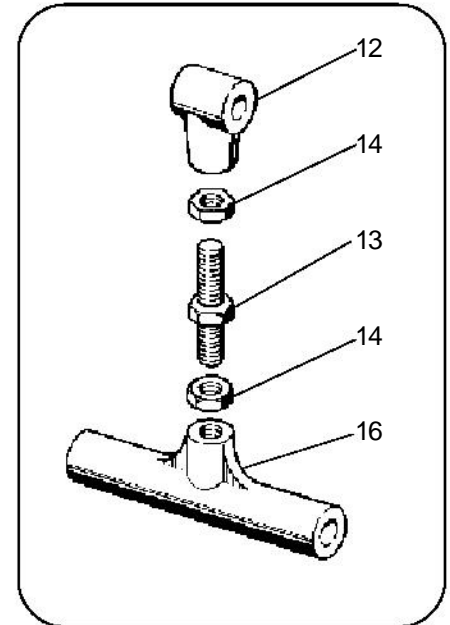

When placing an order for replacement parts, please provide the following information:



1. The LITTELL serial number example: 79602-71
2. A good description of the part or parts required.
3. The LITTELL part number or service manual index number that has been assigned to the part.
4. The source of information from which you found the part illustrated or described. This may be a LITTELL drawing, a service bulletin number, or in some cases, the number is stamped directly on the part.
5. The quantity required.

In the absence of a good part number or description, we ask that you include either a sketch, drawing, or photograph to help us in identifying your needs. If this is not convenient, circle or point to the parts required on a drawing removed from your service manual and forward it with your order. The LITTELL Service Department will send you a new drawing to keep your service manual complete.

**LITTELL** Service Personnel are available World-Wide, to help you with service problems that you may encounter with your **LITTELL** coil processing equipment.

In the event that you encounter difficulty, we suggest that you first contact your local **LITTELL** Representative or the **LITTELL** District Sales office covering your local area. They are familiar with your equipment and operations and may be able to help find the solution to your problem. They are close at hand and can offer prompt service.

If the problem is of a more serious nature, we then recommend that you call or email the **LITTELL** Service Department located at our main office and factory in Schaumburg, Illinois.

Service engineers are available to assist you on the phone, arrange for the shipment of replacement parts, or arrange a service call to your location and at your convenience. All requests for field service must be confirmed by a written purchase order. We will be pleased to quote field service charges upon your request.

**LITTELL**

1211 TOWER ROAD, SCHAUMBURG, ILLINOIS 60173, U.S.A.  
AREA CODE: (630) 622-4700 LITTELL TELEFAX: (630) 622-4747  
SERVICE DEPARTMENT TELEFAX: (630) 622-4748