

SUBJECT:

Safeguarding & Safety Precautions For Cleaning Power Driven Rolls On LITTELL Machines.

WARNING

To prevent serious injury to persons involved with LITTELL Machinery, Read & Comply with all of the following safety instructions.

SAFETY INSTRUCTIONS:

Immediate action, by users of this machinery, must be taken to apply accident prevention safeguards and safety precautions as specified in this report. Due to today's high probability of employees receiving insufficient training or supervision combined with the possibilities of committing unsafe, careless or negligent acts, this precautionary action is mandatory.

To prevent serious injury to persons in your company, use the safety information contained in this report to assist yourself in accomplishing both the required addition and continued use of the necessary safeguards and safety precautions.

Throughout this report the word "USER" means any individual, partnership, corporation, or other form of enterprise which employs, contracts with, hires, benefits from, or is responsible for the persons who install, setup, adjust, operate, service, maintain, repair or work on or around machinery originally manufactured by Littell.

It is the Employer's responsibility to comply with the OCCUPATIONAL SAFETY & HEALTH ADMINISTRATION'S general industry standards, part 1910, Title 29 of the CODE OF FEDERAL REGULATIONS.

PROHIBITED



**KEEP AWAY FROM
REVOLVING ROLLS**

PROHIBITED



**NEVER CLEAN ROLLS
WHILE REVOLVING**

Littell machines containing power driven rolls must be used and cared for safely and require safeguarding to prevent access to roll hazard areas. Present trends indicate that these rolls are high risk and hazardous. They can cause severe injury to fingers, hands, and arms of persons attempting to unsafely clean the rolls or thread material while the rolls are in motion.

These machines are slaves and operate intermittently by command from automatic remote controls. Start and Stop, redundant and irregular, cycling and roller rotation is initiated by remote control sensing of the materials being processed between and within machines while unoccupied and sometimes bored operators look around these machines for something to do.

Injuries to hands, especially those wearing gloves or holding rags, are increasing as persons attempt to wipe rolls during machine operation.

The practice of cleaning these rolls during the automatic stop cycle, regardless of stop time, and during the start and continuous running cycles, is unsafe. No one can be allowed to contact these rolls, even if they synchronize their contact with the automatic stop and restart cycling.

The practice of threading material into these powered rolls while the machine is in its automatic start and stop cycling operation or when the rolls are rotating for any reason is unsafe.

The user must take immediate action to prevent these unsafe practices. To assist in this prevention, safeguarding must be applied. Several safeguard methods are recommended in this report and their proper application depends on the frequency, and purpose of roller access.

This report is not intended to illustrate every safeguard or cleaning method which may be required or to limit the application of safeguarding or cleaning to those shown in this report. It is intended to describe some of the hazards which exist, to require safeguarding and safe cleaning methods, to eliminate or minimize hazards and to define certain responsibilities.

The user shall only allow the operation of Littell power driven roll machines that have been safeguarded as instructed in Littell Safety Awareness Reports No. SAR-101-102 and 108.

The user must provide safe support and physical containment for workers where ladders, stairs, scaffolding or other walking or working surfaces are required for machine service, repair, roll access, cleaning or other similar operations.

To assist users in evaluating machinery safeguarding a "Directory of Safety Literature, Standards, and Regulations" has been included in this report. Users should obtain and review this material immediately.

The popular and common applications that these power driven roll machines were designed for RARELY require frequent roll access or roll cleaning. Therefore, the preferred method of safeguarding is the use of fixed roll enclosures, allowing passage of the processing material only, which are permanently mounted to the main frame of the machinery and require the use of tools for their removal. These enclosures must prevent access to the roll hazards generally referred to as NIP, PINCH, or SQUEEZE points.

Of the few applications that may require special roll access or cleaning, several methods exist and their selection and use must be based on which provides the best safety. However, before evaluating and applying these special safeguards,

consider if they are absolutely necessary or if the frequency of access or cleaning can be diminished enough for safe and practical use of the standard and preferred safeguards. It may be possible to prevent or reduce the exposure to hazards and improve your productivity by the control or elimination of the roll contamination or its cause instead of providing a roll access or cleaning safeguard remedy.

Consider the following preventive methods to eliminate the need for roll cleaning or diminish its frequency.

- Obtain improved quality materials for sliver free slit edges, and spawl, slug, lamination free material.
- Obtain material without surface coatings and apply these coatings after processing through Littell rolls.
- Obtain cleaner material for both external and internal surfaces.
- Process material as soon as possible or oldest inventory first, newest last.
- Maintain cleaner material storage and apply temporary protective wrapping or covers.
- Clean the material outer wraps or surfaces BEFORE processing through Littell rolls.
- Shear off and eliminate outer contaminated coil wraps prior to processing.
- Obtain assistance and participation from your material supplier.

The following are several methods of access or cleaning and possible resulting hazards.

- Shutdown the machine by disconnecting the main power and locking in "off" position. Unbolt and remove standard safeguards to gain roll access.
APPLICATION = Infrequent access.
POSSIBLE HAZARD = Failure to either "Shutdown or Lockout" all power sources in the machine.
- Hinged or movable safeguard, electrically interlocked to provide and maintain an automatic machine shutdown when rolls become accessible.
APPLICATION = Frequent access.
POSSIBLE HAZARD = Circumvention or bypassing of the safeguards sensors, or switches to allow powered roller rotation.
- Fabric cleaning device inserted and stalled within lightly pressurized and slowly rotating rolls without safeguard removal.
APPLICATION = Frequent cleaning.
POSSIBLE HAZARD = Flammable cleaning agent substitute. Unsafe support of worker on large and difficult to reach rolls.

The hazards which may develop in these roll access or cleaning methods result from unsafe procedures, practices, lack of training, insufficient knowledge or safety awareness.

The addition of special safeguards and the use of special cleaning devices is not the sole remedy for accident prevention. To realize maximum protection benefits, the safety precautions in this report must be incorporated into user's safety training programs. Persons involved with Littell machinery must be supervised and tested to determine and continually insure that all have been adequately instructed by demonstrating, with discrete repetition, their awareness and understanding of these safety precautions including other applicable safety practices, codes, standards, and regulations which are not included in this report.

Many accidents have occurred due to a supervisor's lack of training; because of this lack of training, the supervisor is incapable of developing the necessary safety awareness and cannot transfer safe work procedures to others.

Users must make certain that only persons who understand Littell machinery, its intended use, care and safety requirements and who are able to communicate this knowledge be given the responsibility of instructing, training, and supervising others involved with this machinery.

It is the user's responsibility to interpret and to explain all safety precautions and signs to persons who do not read or understand English BEFORE they are allowed to use and care for this machinery.



Train, Instruct and Supervise for Safety...

WARNING
ONLY PERSONS WHO THOROUGHLY UNDERSTAND AND COMPLY WITH ALL OF THE GIVEN SAFETY PRECAUTIONS ARE QUALIFIED TO USE AND CARE FOR LITTELL MACHINERY WHICH HAS BEEN SAFEGUARDED AS INSTRUCTED IN THIS REPORT. MAKE CERTAIN THESE PRECAUTIONS ARE APPLIED IMMEDIATELY.

The user must decide what personal protective safety equipment is required to perform each job safely. Items such as safety glasses, shoes, gloves, helmets, spats, protective sleeves and material handling equipment are common in the metal working industry.

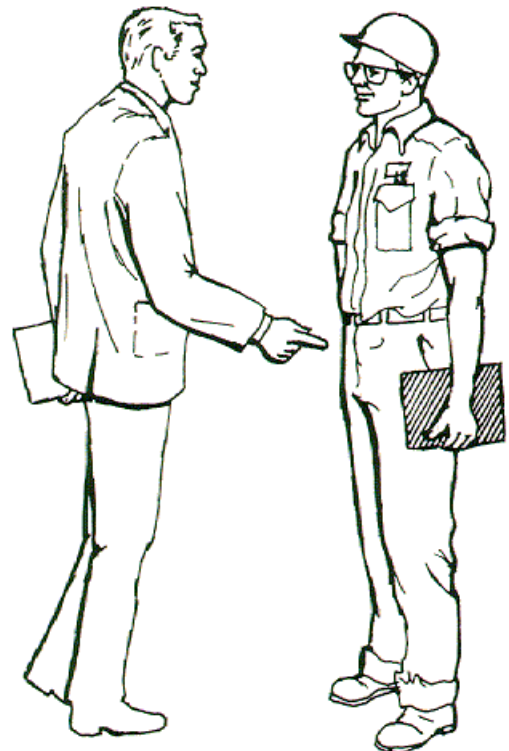

Roll Access Method Using Permanently Mounted Safeguards:

OPERATIONAL SEQUENCE

WARNING

Read and understand all of the safety precautions in this report and within the machine's instruction manual before performing the following sequence.

1. "TURN OFF" the machine using a selector switch or by depressing the "STOP" push-button located on the machine's control station.

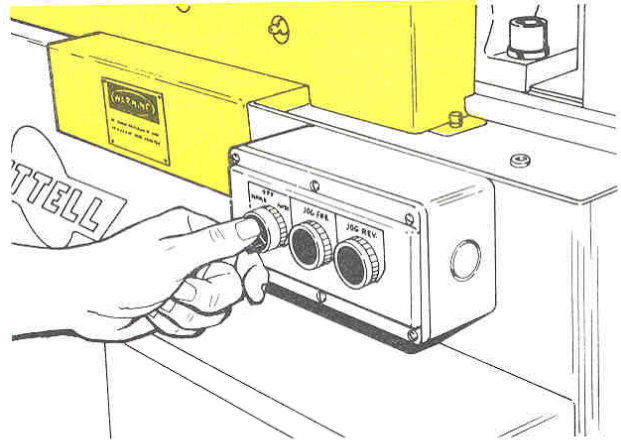

2. Disconnect electrical power supply source by moving the switch lever to the "OFF" position. This switch may be located on the machine's main control panel or on a remotely located electrical enclosure.

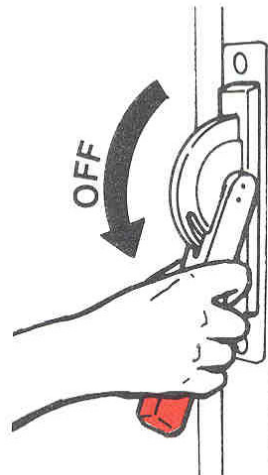

3. Lockout and Tag electrical disconnect switch lever to prevent other persons from accidentally restarting the machine. Apply your own lockout device and do not depend on other lockouts that are presently applied. Try the machine controls as a test to confirm that the electrical power is "OFF".

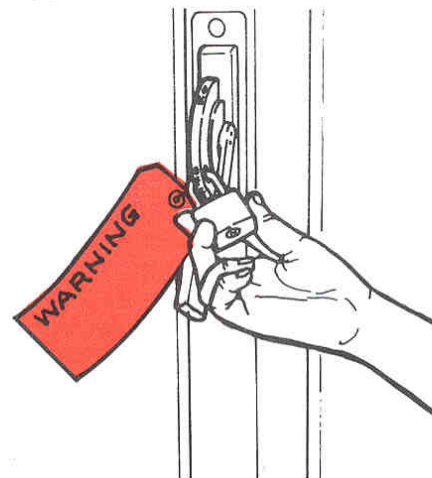

Roll Access Method Using Permanently Mounted Safeguards: (Cont'd)

OPERATIONAL SEQUENCE

4. Exhaust, vent, lockout and tag hydraulic and pneumatic pressure that, as stored or trapped energy, could cause dangerous machinery motion.

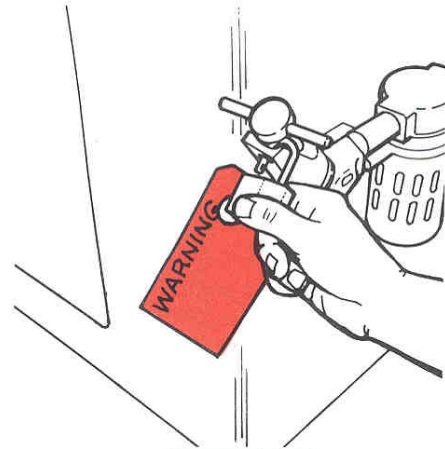

5. Remove the necessary roll safeguard. The removal of one or two guards above the rolls is normally sufficient for adequate roll access.

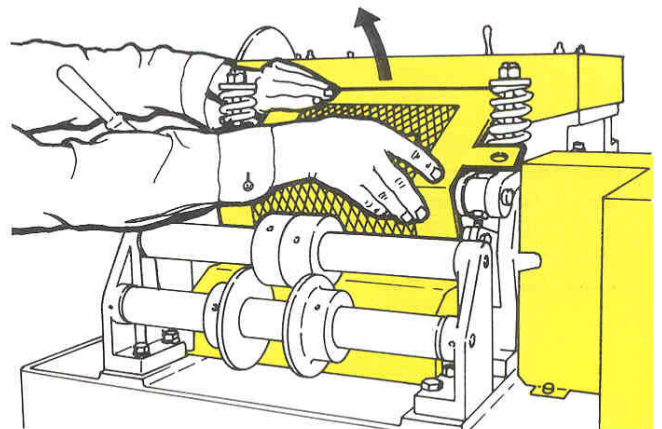

6. If required raise the feed or pinch rolls.

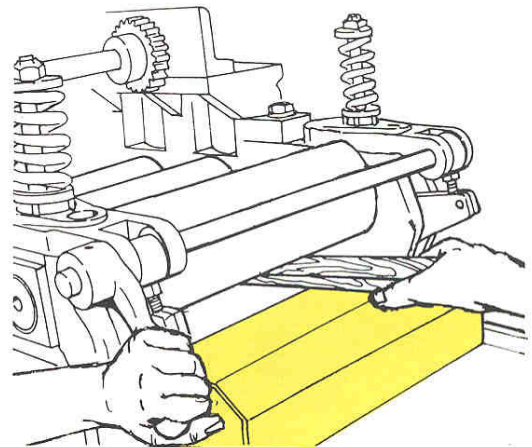

CAUTION

Always make certain all machinery components will maintain a safe position during all maintenance and repairs by using adequate physical blocking, restraint, and control procedures. Never depend upon the machine's hydraulic or pneumatic power to hold or maintain any components in a constant position.

Roll Access Method Using Permanently Mounted Safeguards: (Cont'd)

OPERATIONAL SEQUENCE

7. Wipe rolls clean - use a brush on textured roll surfaces - if necessary. Cleaning fluids can be hazardous. Read and comply with their manufacturer's instructions and safety precautions on safe and proper use.

CAUTION:

USE NON-FLAMMABLE NON-TOXIC CLEANING FLUID. MACHINES ARE NOT EQUIPPED WITH EXPLOSION PROOF CONTROLS OR ELECTRICAL DEVICES.

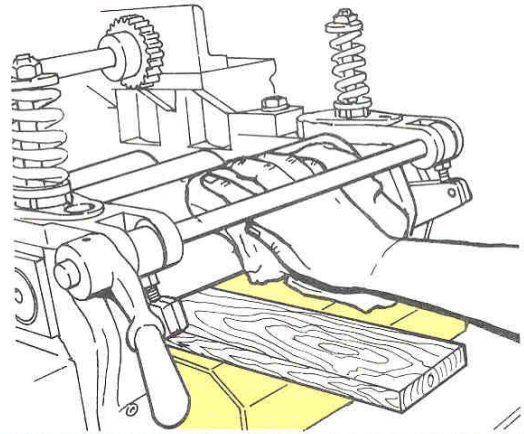

8. If required - rotate the pinch or straightener rolls by turning the main drive coupling by hand. Feed rolls can be rotated by turning the main drive shaft. See each machine's instruction manual for additional information.

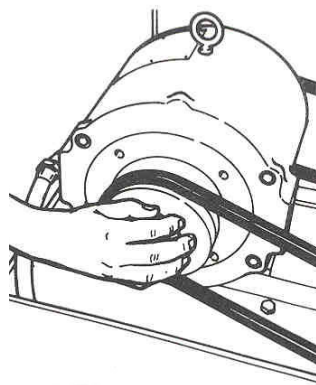

STRAIGHTENER DRIVE

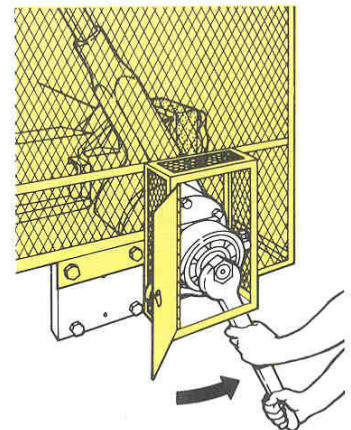

ROLL FEEDER

9. Remove all tools and materials.
10. Unblock all Rolls.
11. Replace ALL Safeguards and permanently fasten them.
12. Return all power sources when all persons are safely clear and it's proper to do so.

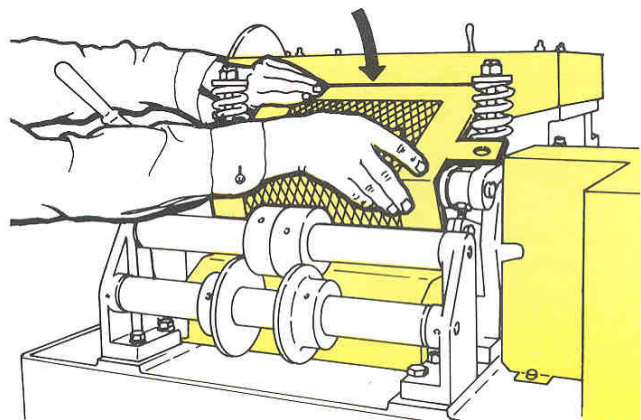

Roll Access Method Using Hinged or Moveable Safeguards Electrically Interlocked:

OPERATIONAL SEQUENCE

WARNING

Read and understand all of the safety precautions in this report and within the machine's instruction manual before performing the following sequence.

1. "TURN OFF" the machine using a selector switch or by depressing the "STOP" push-button located on the machine's control station.

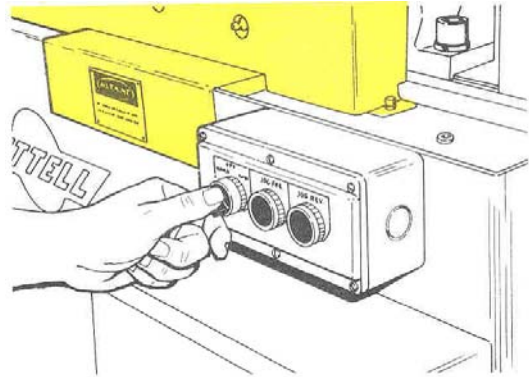

2. Disconnect electrical power supply source by moving the switch lever to the "OFF" position. This switch may be located on the machine's main control panel or on a remotely located electrical enclosure.

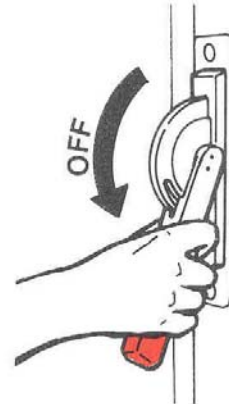

3. Lockout and Tag electrical disconnect switch lever to prevent other persons from accidentally restarting the machine. Apply your own lockout device and do not depend on other lockouts that are presently applied. Try the machine controls as a test to confirm that the electrical power is "OFF".



4. Exhaust, vent, lockout and tag hydraulic and pneumatic pressure that, as stored or trapped energy, could cause dangerous machinery motion.

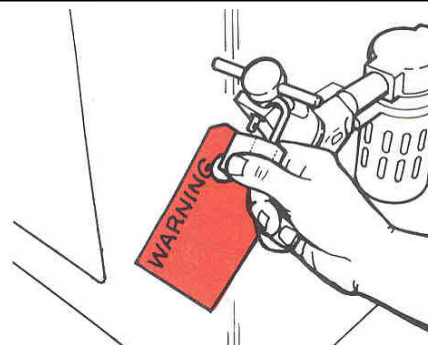

Roll Access Method Using Hinged or Moveable Safeguards Electrically Interlocked (Cont'd)

OPERATIONAL SEQUENCE

5. Open Roll Safeguard. Never tape, jam, or circumvent a safeguard sensor detector, or switch to allow propulsion of rolls with safe guards removed.

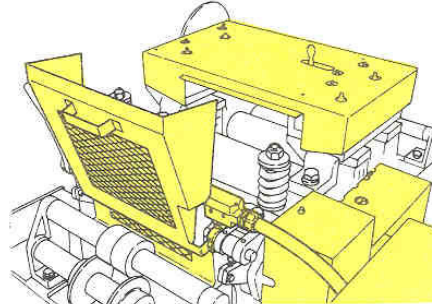

6. If required raise the feed or pinch rolls.

CAUTION

Always make certain all machinery components will maintain a safe position during all maintenance and repairs, by using adequate physical blocking, restraint, and control procedures. Never depend upon the machines hydraulic or pneumatic power to hold or maintain any components in a constant position.

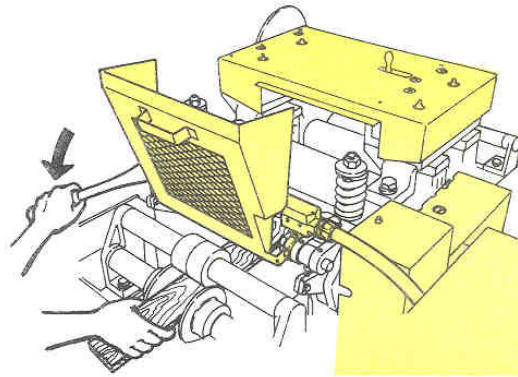

7. Wipe rolls clean - use a brush on textured surfaces - if necessary. Cleaning fluids can be hazardous. Read and comply with their manufacturers instructions and safety precautions on safe and proper use.

CAUTION

USE NON-FLAMMABLE NON-TOXIC CLEANING FLUID. MACHINES ARE NOT EQUIPPED WITH EXPLOSION PROOF CONTROLS OR ELECTRICAL DEVICES.

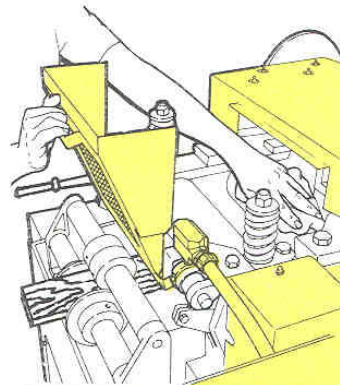

8. If required - rotate the pinch or straightener rolls by turning the main drive coupling by hand. Feed rolls can be rotated by turning the main drive shaft. See each machine's instruction manual for additional information.

9. Remove all tools and materials.

10. Unblock all Rolls.

11. Replace ALL Safeguards and permanently fasten them.

12. Return all power sources when all persons are safely clear and it's proper to do so.

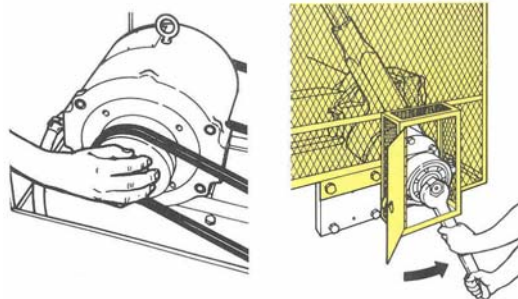

CAUTION:

Safeguards with electrical interlocks shall not automatically "RESTART" the machine when returned to their protective position.

Roll Cleaning Method Using Fabric Cleaning Device Without Safeguard Removal:

INTENDED APPLICATION:

Semi-Automatic method and device for cleaning Littell powered rolls without removal of roll safeguards.

Method

1. Fabric cleaning device is used to:
 - A. Transmit cleaning fluid to roll surfaces.
 - B. Provide scrubbing effect on rolls.
 - C. Collect roll contaminants.
2. Fabric must be saturated with non-flammable and non-toxic cleaning fluid prior to use.

CAUTION:
USE NON-FLAMMABLE, NON-TOXIC CLEANING FLUID. MACHINES ARE NOT EQUIPPED WITH EXPLOSION PROOF CONTROLS OR ELECTRICAL DEVICES.

3. The fabric is full roll width and has a rigid, tapered lead edge for threading through straightener head.
4. Cleaning device contains a removable restraining bar used for:
 - A. Actuation of Entry and Exit Pinch Roll pressure release controls to prevent fabric and drive overload. (Used only on Pneumatic operated rolls.)
 - B. Prevent fabric from being passed through the machine during cleaning operation.
 - C. Storage handles for hanging up fabric.
5. Scrubbing action is developed by inching the main drive to propel rolls against fabric for several minutes.
6. Use of a durable, heavily stitched fabric which can be cleaned and reused.
7. Frequency of use depends on contaminate type, amount and product quality control.

TYPICAL STRAIGHTENING MACHINE

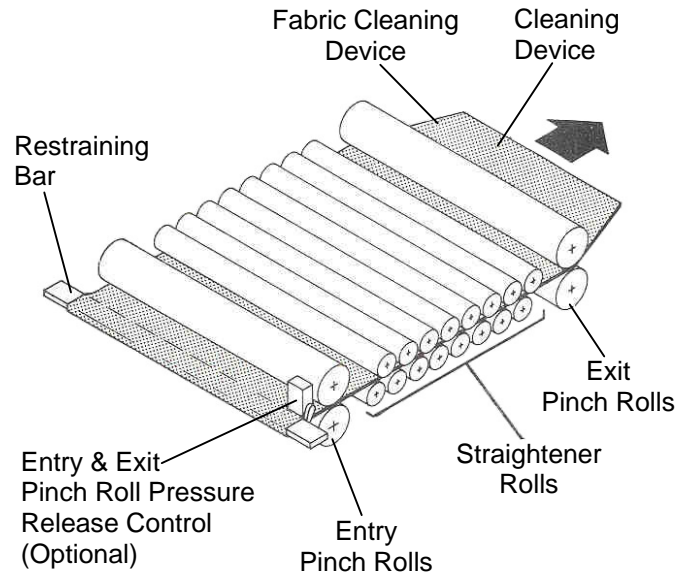

TYPICAL ROLL FEED MACHINE

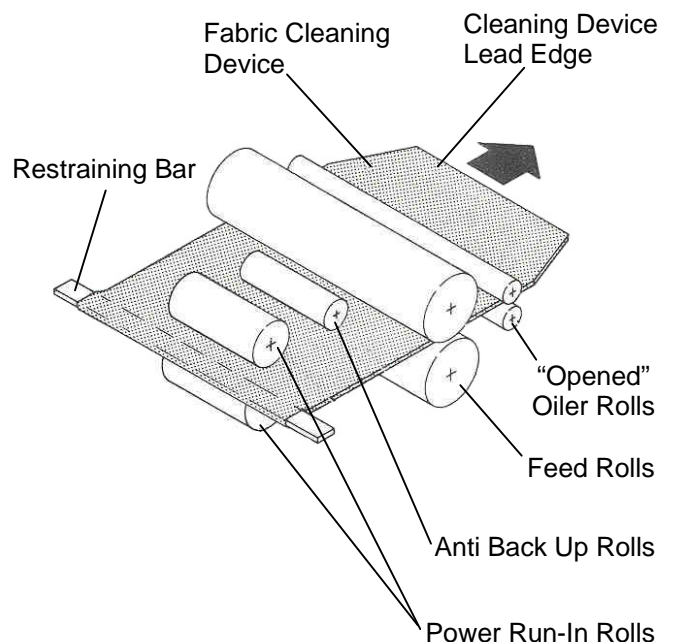

Roll Cleaning Sequence Using Fabric Cleaning Device: OPERATIONAL SEQUENCE

WARNING

Read and understand all of the safety precautions in this report and within the machine's instruction manual before performing the following sequence.

1. "TURN OFF" the machine using a selector switch or by depressing the "STOP" push-button located on the machine's control station.

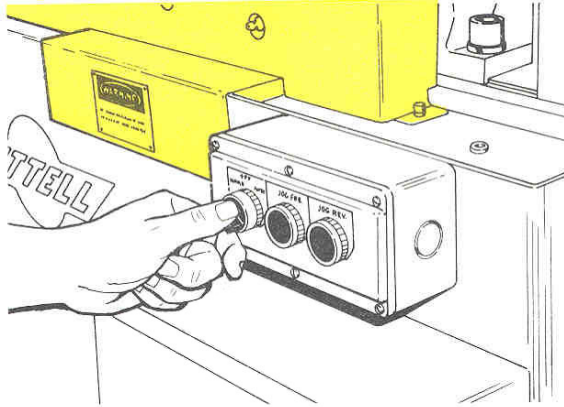

2. Open the entry Feed or Pinch Rolls and adjust the strip edge guides to their widest position.

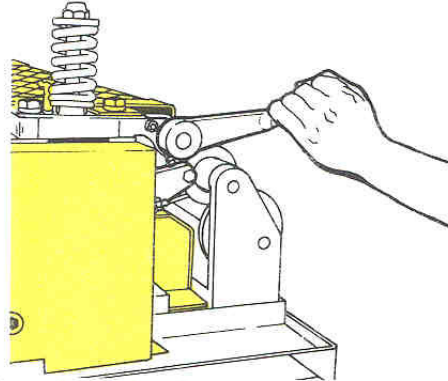

3. Insert the stiff leading end of cleaning fabric between entry rolls.

CAUTION:

NEVER thread or enter the fabric cleaning device into revolving rolls.

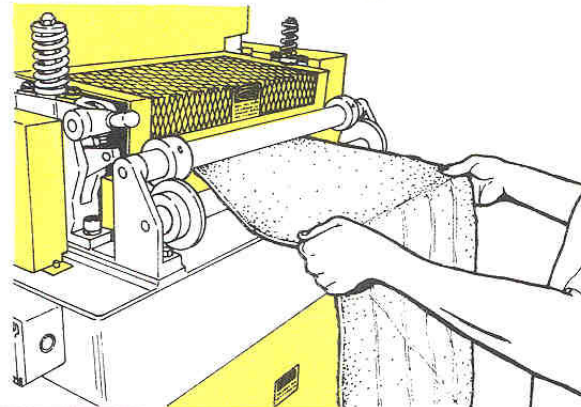

4. Lower Feed or Pinch Rolls until lightly pressurized against fabric.

CAUTION:

Rolls operated by pneumatic pressure require pressure release controls to prevent fabric and drive overload.

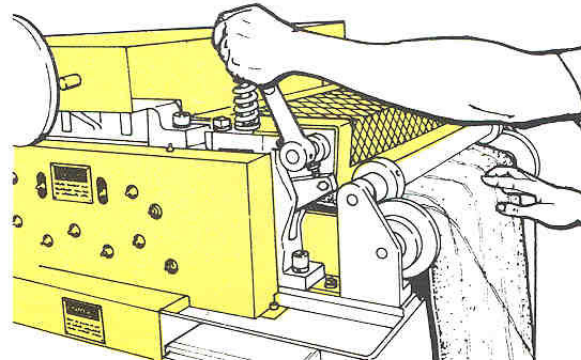

Roll Cleaning Sequence Using Fabric Cleaning Device: (Cont'd)

OPERATIONAL SEQUENCE

5. Turn to "MANUAL" using the selector switch located on the machine's control station. Jog main drive to SLOWLY propel fabric through all rolls until restraint bar in fabric tail stalls against entry frames.

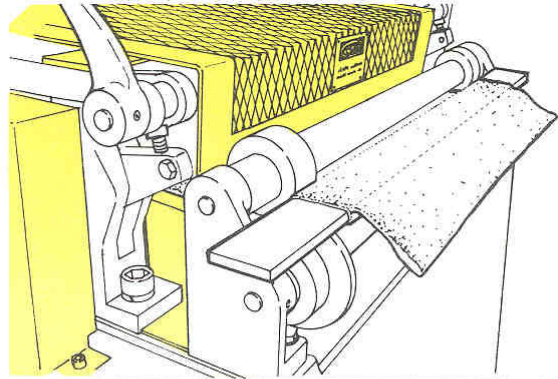

CAUTION

KEEP HANDS CLEAR FROM FABRIC AND IT'S RESTRAINT BAR WHEN PROPELLING THE ROLLS.

6. Continue to slowly Jog and propel rolls against fabric causing a scrubbing action for several minutes.

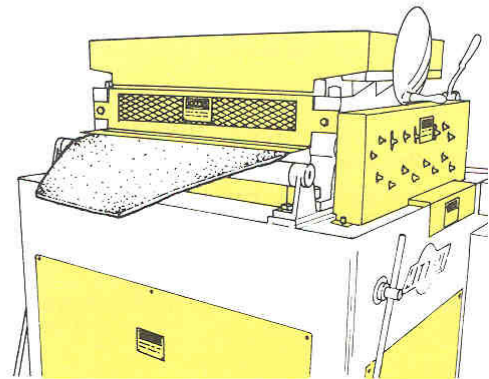

7. Slowly Jog reverse rolls to remove fabric from rolls.
8. "TURN OFF" the machine.
9. Return fabric to storage hangers. Clean fabric when necessary. Cleaning fluids can be hazardous. Read and comply with their manufacturer's instructions and safety precautions on safe and proper use.

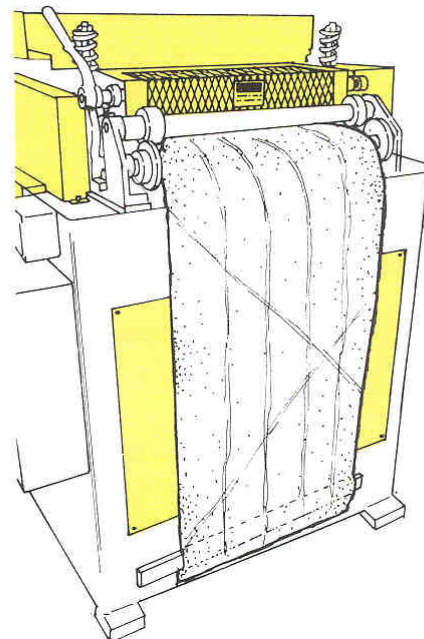

CAUTION:

USE NON-FLAMMABLE, NON-TOXIC CLEANING FLUID. MACHINES ARE NOT EQUIPPED WITH EXPLOSION PROOF CONTROLS OR ELECTRICAL DEVICES.

Safety Precautions:

WARNING

READ AND UNDERSTAND ALL OF THE FOLLOWING:

FAILURE TO COMPLY WITH ANY ONE PRECAUTION MAY CAUSE SERIOUS BODILY INJURY TO YOURSELF OR OTHERS.

ONLY PERSONS WHO THOROUGHLY UNDERSTAND AND COMPLY WITH ALL OF THE FOLLOWING SAFETY PRECAUTIONS ARE QUALIFIED TO SAFELY USE AND CARE FOR LITTELL MACHINERY.

- Read and comply with the machine instruction manual before servicing, repairing, maintaining, cleaning, or caring for this machine.
- Before servicing, repairing, maintaining, or cleaning, always use proper tag and lockout safety procedures to exhaust, disconnect, and control all hazardous energy and motion, both entering and contained within this machine.
- Before caring for this machine, read and comply with all safety warnings.
- Know the location and access to the emergency stop controls.
- Know what machine safeguards exist and their proper location.
- Never leave the machine unattended with the power turned on.
- Never operate these machines with their safeguards removed or missing. Discontinue using until all are replaced and properly functioning.
- These machines start automatically. Always maintain a safe clearance from them and the entering and exiting materials.
- Before servicing, maintaining, cleaning, or unjamming a feeder and scrap cutter which is propelled and controlled by a punch press, always make certain the press maintains a safe stop condition and is disarmed per Federal Regulation OSHA-1910-217. to prevent accidental feed propulsion and transmittal of any hazardous energy or motion.
- Standard roll enclosures are permanently mounted and require tools for removal. They are not designed nor intended to allow rapid removal or frequent access to the rollers. If a special application requires such access, special safeguarding must be requested and installed that will cause an automatic “Shutdown” of the machine to occur and be maintained when the roll enclosure is removed or the safeguarded area is unsafely penetrated.
- Protect yourself and others from injury by never bypassing, or eliminating any safety device, feature or procedure.
- Never tape, jam, or circumvent a safeguard sensor, detector, or switch to allow propulsion of rolls with safeguards removed.

Safety Precautions: (Cont'd)

- Never position your hands on or near revolving rolls for any reason.

PROHIBITED



**KEEP AWAY FROM
REVOLVING ROLLS.**

- Never place your hands, with gloves or rags, on revolving rolls for any reason.

PROHIBITED



**NEVER CLEAN ROLLS
WHILE REVOLVING**

- Never thread or enter the Fabric Cleaning device into revolving rolls.

TO CLEAN SAFELY

1. STOP THE MACHINE.
2. OPEN ENTRY ROLLS.
3. ENTER THE FABRIC.
4. CLOSE ENTRY ROLLS.
5. REMOVE HANDS FROM FABRIC.
6. START MACHINE.
7. INCH/JOG FABRIC INTO ROLLS.

- Follow only your instructed work procedures that you have been trained for. If a new or unfamiliar situation arises, ask your foreman for safe instructions before proceeding.

- Never use the straightener control arm or remote loop sensing device as a manual hand control to start and stop the rolls while you or others wipe or clean the rolls.

- Never wear clothing or jewelry that could cause part of the body to be caught or dragged into the machinery.

- Stay alert, don't become careless or over confident. Avoid preoccupation, inattention, distraction and talking when caring for this machine.

- Maintain a sense of personal safety awareness. Observe all safety warnings and practices. Be on the lookout for hazardous conditions. Report hazards and obtain instruction for their control from your supervisor.

Safety Precautions: (Cont'd)

- Only use NON-FLAMMABLE - NON-TOXIC cleaning fluids. Machines are not equipped with explosion proof controls or electrical devices.
- Cleaning fluids can be hazardous. Read and comply with their manufacturer's instructions and safety precautions on safe and proper use.
- Never rely or depend upon the straightener control arm or remote loop sensing device stop control to MAINTAIN a machine stop condition.
- Before and during servicing, repairing, maintaining, or cleaning, always maintain a machine shutdown by tagging and locking out the electrical disconnect switch located on the machine control panel or upon a nearby main power supply source to prevent other persons from accidentally restarting the machine.
- When more than one person services, repairs, maintains or cleans these machines, each person should be protected by applying their own power lockout device and should not depend on other lockouts for protection.
- Pulling fuses is not a substitute for locking out. Removing a fuse is no guarantee the circuit is dead and there is nothing to prevent fuse replacement during your exposure to the machine's hazards.
- Locking out one source of power may not be sufficient. Vent, exhaust and lockout hydraulic and pneumatic pressure that, as stored or trapped energy, could cause dangerous machinery motion.
- Before caring for this machine, try the machine controls as a test that the power source is "OFF" or safely controlled.
- Always make certain all machinery components will maintain a safe position during all maintenance and repairs by using adequate physical blocking, restraint, and control procedures. Never depend upon the machine's hydraulic or pneumatic power to hold or maintain any components in a constant position.
- Only qualified electrical, pneumatic, or hydraulic personnel should work on respective circuitry.
- Never over-reach, climb, or stand on places other than properly designated ladders, steps and walkways.
- Use personal protective equipment and clothing such as safety glasses, helmets, gloves, spats, shoes, and protective sleeves as required to suit the operation.
- Never start the press, shear, feeder, or straightener until all scaffolding, ladders, tools and other repair or adjusting equipment has been safely cleared away.
- Before operating machinery, always make certain all persons are in safe location.

A SAFETY FIRST WARNING

It is impossible to foresee all possible uses, and applications of this machine. Therefore, it is also impossible to warn you in advance of every possible hazard, or to tell you that this machine will always be absolutely "hazard free". Your best protection against injuries to yourself or others is to always be cautious and remind yourself to think "SAFETY FIRST" before attempting any questionable, unfamiliar, infrequent, physical involvement with this machine that you have NOT been specifically trained for. When these situations arise, act cautiously think "SAFETY FIRST", and protect yourself and others by requesting detailed safety instructions and related training from your management before attempting any such involvement for the care and use of this machine.

DIRECTORY SAFETY LITERATURE / STANDARDS / REGULATIONS	
<p>The following is a list of some of the Federal Regulations and other safety literature which users should obtain and review before applying safeguards to Littell Products. Each publication has been cross referenced to some (but not necessarily all) of the areas in which they are involved. Many other publications exist (such as American National Standards) and can be easily identified in the "Sources of Standards" listed in the OSHA Federal Regulations below.</p>	
APPLICABLE SAFETY LITERATURE / STANDARDS / REGULATIONS	INVOLVEMENT AREA
<p>"Accident Prevention Manual for Industrial Operations." By National Safety Council - Chicago, IL 60611</p>	<ul style="list-style-type: none"> ● Complete Sourcebook for industrial safety.
<p>"Guards - Illustrated - Ideas for Mechanical Safety." By National Safety Council - Chicago, IL 60611</p>	<ul style="list-style-type: none"> ● Machine guarding Methods and devices.
<p>Littell Safety Awareness Report No. SAR-100 - Unbanding Coils. Littell Safety Awareness Report No. SAR-101 - Safeguarding and Safety Precautions for Feeding Machines. Littell Safety Awareness Report No. SAR-102 - Safeguarding and Safety Precautions for Coil Strip Straightening Machines. Littell Safety Awareness Report No. SAR-103 - Safeguarding and Safety Precautions for Uncoilers.</p>	<ul style="list-style-type: none"> ● Specific safety instructions and safety precautions on the safe-guarding, care and use of Littell products.
<p>OSHA - Part 1910 - Subpart D - Walking and Working Surfaces. SECTIONS: 1910.21 Definitions. 1910.22 General Requirements. 1910.23 Guarding Floor and Wall Openings and Holes. 1910.24 Fixed Industrial Stairs. 1910.25 Portable Wood Ladders. 1910.26 Portable Metal Ladders. 1910.27 Fixed Ladders. 1910.28 Safety Requirements for Scaffolding. 1910.31 Sources of Standards.</p>	<ul style="list-style-type: none"> ● Access to Press Crank Shaft of Feeders - Drive Adjustments. ● Protection from Floor Pits for Strip Loop Storage. ● Access to "Hard To Reach" areas of large machinery for servicing or repairing.
<p>OSHA - Part 1910 - Subpart J - General Environmental Controls. SECTIONS: 1910.144 Safety Color Code for marking Physical Hazards. 1910.145 Specifications for Accident Prevention Signs and Tags. 1910.147 Sources of Standards.</p>	<ul style="list-style-type: none"> ● Regulations for identifying and communicating hazards
<p>OSHA - Part 1910 - Subpart N - Material Handling and Storage. SECTIONS: 1910.176 Handling Material - General. 1910.178 Powered Industrial Trucks. 1910.179 Overhead and Gantry Cranes. 1910.184 Slings. 1910.189 Sources of Standards.</p>	<ul style="list-style-type: none"> ● Safe care and use during service or repairs of machines. ● Safe Coil Handling & Loading. ● Safe Scrap Handling & Unloading.
<p>OSHA - Part 1910 - Subpart O - Machinery and Machine Guarding. SECTIONS: 1910.211 Definitions. 1910.212 General Requirements for All Machines. 1910.217 Mechanical Power Presses. 1910.219 Mechanical Power Transmission Apparatus. 1910.221 Sources of Standards.</p>	<ul style="list-style-type: none"> ● Safeguarding of all machine hazards. ● Mechanical Power Presses used with Littell Roll Feeds Safely.
<p>OSHA - Part 1910 - Subpart S - Electrical. SECTIONS: 1910.308 Application. 1910.309 National Electrical Code.</p>	<ul style="list-style-type: none"> ● Safe addition of electrical interlocks. ● Safe care and use of machinery with electrical power.
<p>American National Standard Institutes. Safety Requirements for the Construction, Care, and Use of Shears No. ANSI-B11.4. American National Standard Institutes. Safety Requirements for the Construction, Care, and Use of Mechanical Power Presses No. ANSI-B11.1</p>	<ul style="list-style-type: none"> ● Safe care and use when combined with Littell Products.

Additional copies of this Safety Awareness Report are available and supplied free to all our product users when requested. We recommend that users place this report in existing Littell machinery instruction or service manuals which should always be readily available to everyone involved with this machinery allowing them to maintain familiarity with all safeguards, their purpose, location, and warnings.

If you should need additional information or copies contact the Littell Service Department.

Although this report is not a "SAFETY CODE OR STANDARD", the addition of safeguarding and adherence to the safety precautions contained in this report will assist users in complying with the existing Federal Regulations.

This Safety Awareness Report was produced and freely distributed because Littell cares about the safety of its product users. Please help reduce hazards and prevent accidents by complying with its instructions.

Special note:

LITTELL assumes no responsibility in connection herewith, nor can it be assumed that all acceptable safety measures are contained in this publication, or that other additional measures may not be required under particular or exceptional circumstances or conditions.

LITTELL, LLC

1211 TOWER ROAD
SCHAUMBURG, ILLINOIS 60173, U.S.A.
PHONE: (630) 622-4700
LITTELL FAX: (630) 622-4747
SERVICE DEPARTMENT FAX: (630) 622-4748