

SECTION V
MICRO-RUNNING ADJUSTMENT RACK

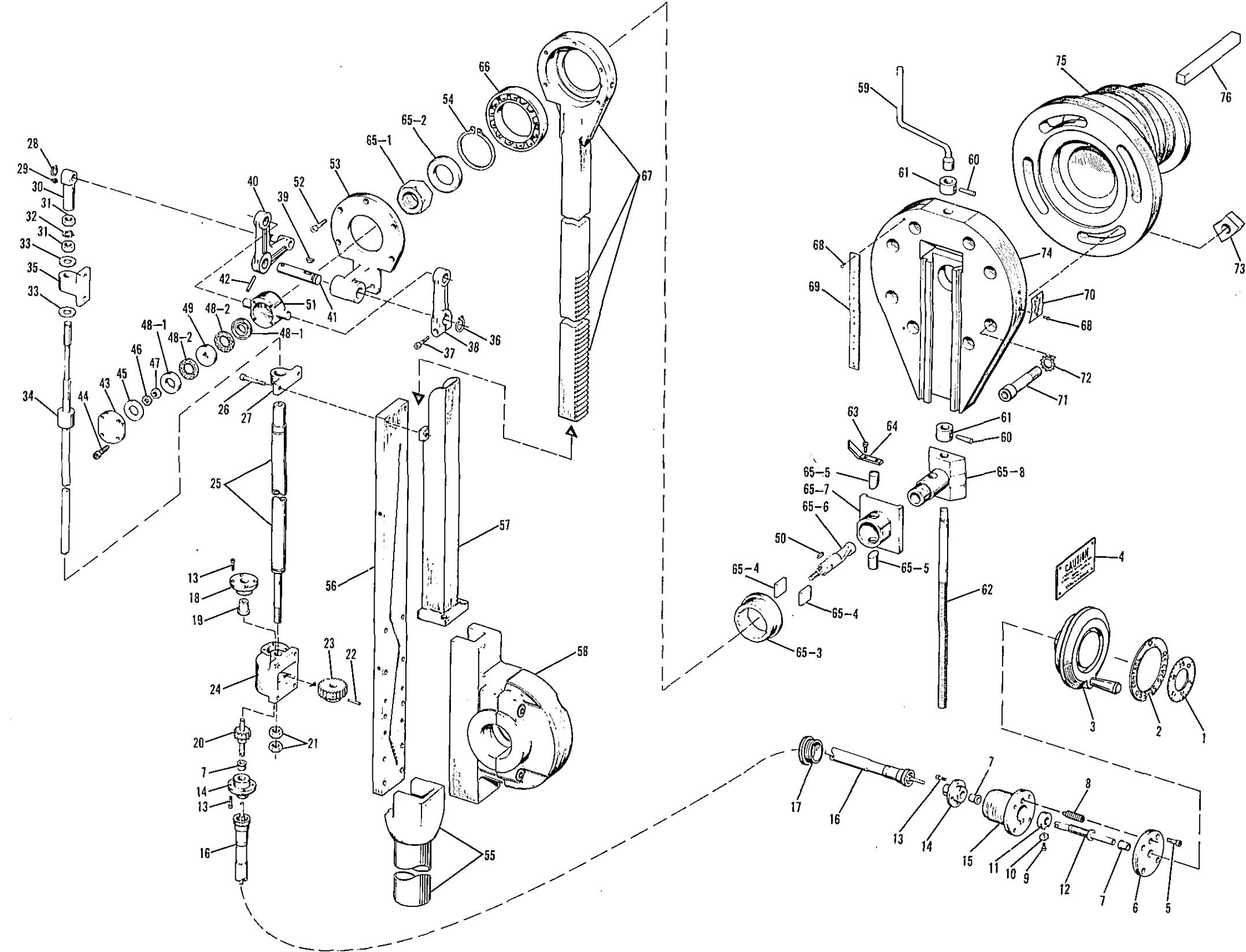

This micro-running adjustment is used on high speed presses running progressive dies where extreme accuracy is required. The micro-running adjustment enables the operator to set up the job and increase the speed to the maximum of the press and secure the very highest feeding accuracy possible. A general description of the set up of this has been given in section 1, part 5, page 1-7. Whenever a new feed length setting is made, the micro-running adjustment handle should be turned so that there are approximately the same number of rotations for increasing as for decreasing the feed length. In other words, the micro-running adjustment should be brought to the mid-point. One other caution, the micro-running adjustment should not be changed unless the feed and press are operating. If the accuracies desired are not secured, check 65 micro-slider block assembly, 62 adjusting screw, 40 actuator arm and pin, 38 actuator arm, 51 the thrust box, and 67 ball bearing rack. Any of these items which show excessive wear or extreme looseness should be replaced to enable you to secure the required accuracies.

Item 65, the Micro-Slider Block Assembly is sold only as an assembly. The individual parts are not sold separately. However, after a customer has secured a new replacement, the unit on his machine can be returned to Littell Machine Co. for re-conditioning at a nominal charge. This will give him a spare which will be in first class operating condition.



INDEX NO.	DESCRIPTION
1	Face - Dial
2	Plate - Instruction
3	Handwheel
4	Plate - Caution
5	Screw - Socket-head Cap
6	Cap - Adjusting Screw
7	Bushing - Flanged
8	Plunger - Spring
9	Screw - Socket-head Cap
10	Key - Stop nut
11	Nut - Stop
12	Screw - Adjusting
13	Screw - Socket-head Cap
14	Adapter - Flexible Cable
15	Housing - Adjusting
16	Cable Assembly
17	Bushing - Insulated male
18	Cover - Gear box
19	Bushing - Flanged
20	Shaft - Drive Gear
21	Nut - Hex, Jam
22	Pin - Taper
23	Gear - Spur
24	Gear box
25	Tube - Torque
26	Screw - Socket-head Cap
27	Pillow Block - Lower
28	Ring - Retainer
29	Fitting - Grease
30	Link - Actuator Arm Adjustment
31	Nut - Hex Jam
32	Washer - Shakeproof, Lock
33	Washer - Hardened Thrust
34	Shaft - Adjusting
35	Pillow Block - Upper
36	Ring - Retainer
37	Screw - Socket-head Cap
38	Arm - Actuator
39	Key - Woodruff
40	Arm and Pin - Actuator
41	Pin - Actuator
42	Pin - Roll
43	Cover - Thrust Box
44	Screw - Socket-head Cap

INDEX NO.	DESCRIPTION
45	Cushion - Thrust Box
46	Nut - Hex, Jam
47	Nut - Hex, Full
48	Bearing - Thrust
	Consisting of:
	48-1 Raceway
	48-2 Retainer - Ball
49	Button - Thrust, Cam Pin
50	Key - Cam ramp
51	Thrust Box
52	Screw - Socket-head Cap
53	Bracket - Actuator
54	Ring - Retainer
55	Guard - Lower Rack
56	Cover - Rack Guide
57	Guard - Upper Rack
58	Guide Assembly - Rack
59	Wrench - Adjusting Screw
60	Pin - Taper
61	Collar - Adjusting Screw
62	Screw - Adjusting
63	Screw - Socket-head Cap
64	Pointer - Slider Block
65	Assembly - Slider Block Micro
	Consisting of:
	65-1 Nut - Slider Block
	65-2 Washer - Slider Block
	65-3 Ring - Retainer
	65-4 Plate - Key
	65-5 Push Rod - Cam Ramp Pin
	65-6 Pin - Cam Ramp
	65-7 Spacer - Rear Bearing
	65-8 Slider Block
66	Bearing - Ball
67	Rack - Ball-bearing
68	Screw - Self-tapping
69	Scale - Feed
70	Plate - Timing
71	Screw - Socket-head Cap
72	Washer - Shakeproof, Lock
73	Nut - Disc Face
74	Face - Disc
75	Hub - Disc
76	Key - Disc Hub